

# Indigo

QUALITY INKJET PRODUCTS

## REFILL INSTRUCTIONS

I.P.S, Unit 5, Mill Street Industrial Estate, Abergavenny, NP7 5HE  
TEL: 01873 854913

### HP Deskjet 300/400/500/600 Colour Cartridges

(51625a + 51649a)

1. Remove the cartridge from the printer.
2. To remove cartridge lid squeeze green/blue top to break the glue using either a vice or g-clamp. To separate the two sections turn the cartridge upside down and twist of the black portion.
3. Once the top is removed you will be presented with three chambers each containing sponge. **Important note:-** the sponges will be white. This is because the sponge is made too big to allow for thermal expansion of the ink with room temperature. Do not completely saturate the sponge as the cartridge will be too full and will either leak or put too much pressure on the printhead which will affect the cartridge's ability to print.
4. Draw 5 ml of ink into the syringe.
5. Push the syringe into the sponge as far as it will go, draw the nozzle back slightly.
6. Inject the ink very very slowly (this is very important as it will avoid air clotting and give the sponge time to absorb the ink).
7. Blot any ink which drips from the printhead immediately with a tissue.

### HP 700/ 800/900 series Colour Cartridges

(51641A/C1823A/D/G/C6578D/C6625A)

- ◆ Remove the cartridge from the printer.
- ◆ Locate the three plugs on top of the cartridge and push them into the cartridge using a ball point pen or similar object.
- ◆ Follow the instructions above from step three onwards.

### LEXMARK

#### Colour cartridge

- ◆ Remove cartridge from printer.
- ◆ Remove the coloured top by placing a sharp sturdy knife in between the coloured lid and the black bottom.
- ◆ Follow the HP instructions from step 3 onwards.

#### Black cartridge

- ◆ Locate the slit on the top of the cartridge and widen using an 1/8" or smaller drill bit. Then inject 15 ml of ink directly into the sponge SLOWLY.

### EPSON

- ◆ Remove cartridge from the printer (NEVER try to fill in situ).
- ◆ Draw 10 ml of ink into the syringe.
- ◆ Locate the top hole underneath the label on the top of the cartridge.
- ◆ Insert the syringe needle into this hole as far as it will go and pull back slightly. Orientate cartridge as shown in the diagram.
- ◆ Inject ink into the cartridge very slowly allowing the sponge time to absorb the ink. If ink drips out of the outlet hole STOP this means your cartridge is full.
- ◆ DO NOT seal the exit hole as this will cause an air lock.

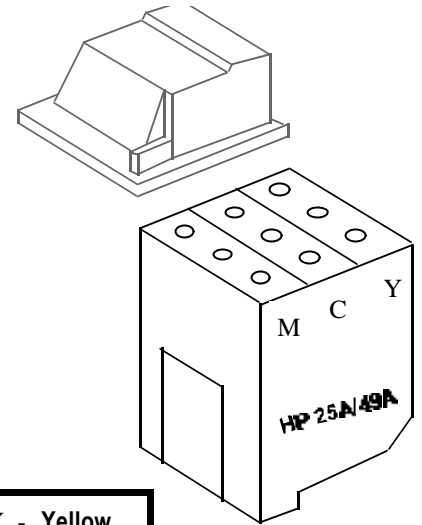

Y - Yellow  
M - Magenta  
(Red)  
C - Cyan  
(Blue)

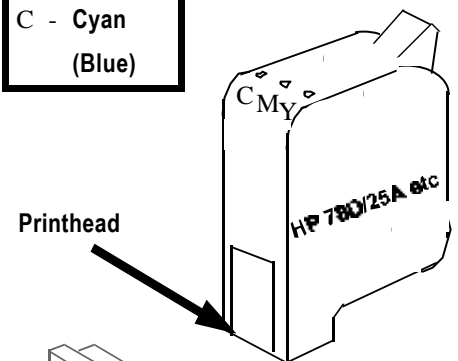

Printhead

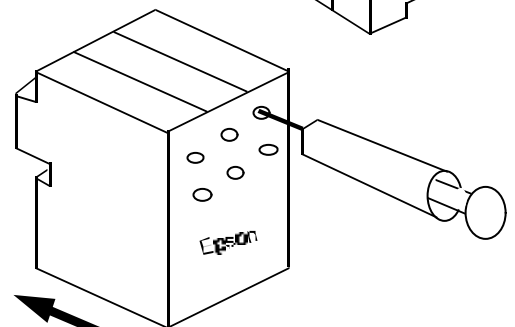
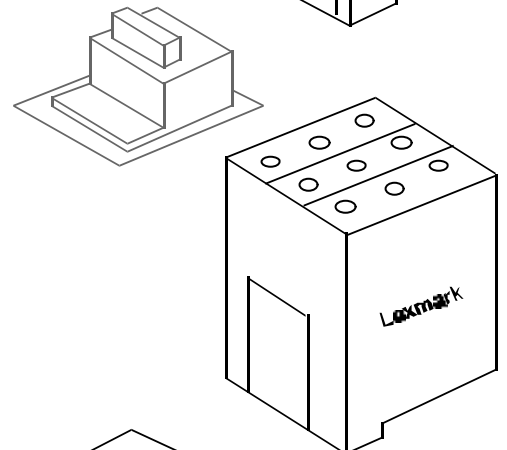

Cartridge  
on its side

## CANON

### BC-05 colour cartridge

- ◆ Locate the breather holes on the side of the cartridge as shown in the diagram.
- ◆ Using a small drill bit (approx 1/8") or curtain hook. Drill out the three holes, this will remove the three plugs.
- ◆ Draw up to 6 ml of ink into the syringe.
- ◆ Using a syringe without the needle, press the syringe tightly into the hole.
- ◆ Inject the ink slowly into the relevant section until it runs clear, out of the printhead. (Ignore the froth)

### BC-01/02 Black cartridge

- ◆ Follow the colour instructions using 20 ml of black ink. After filling shake the cartridge to make sure it will not leak in the printer. (the cartridge weighs 59g when full)

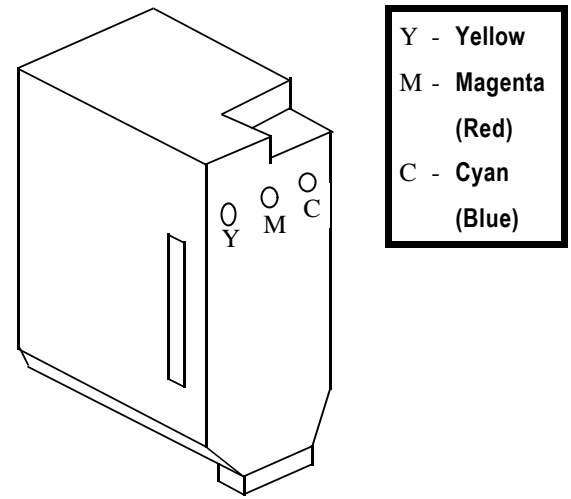

## CANON 2000/4000/5000 series

### (BCI-21)

#### Black cartridge

- ◆ Remove the cartridge from the printer and printhead.
- ◆ Turn the cartridge upside down as shown in the diagram.
- ◆ Draw 7 ml of ink into the syringe.
- ◆ Drip ink onto the sponge until it drips out of the hole on top of the cartridge. (DO NOT inject the syringe into the sponge at the bottom of the cartridge as this will break apart the sponge)

#### Colour cartridge

- ◆ Remove the raised portion at the top of the cartridge as shown in the diagram, using a sharp sturdy knife.
- ◆ Follow the black instructions using 5 ml of ink.

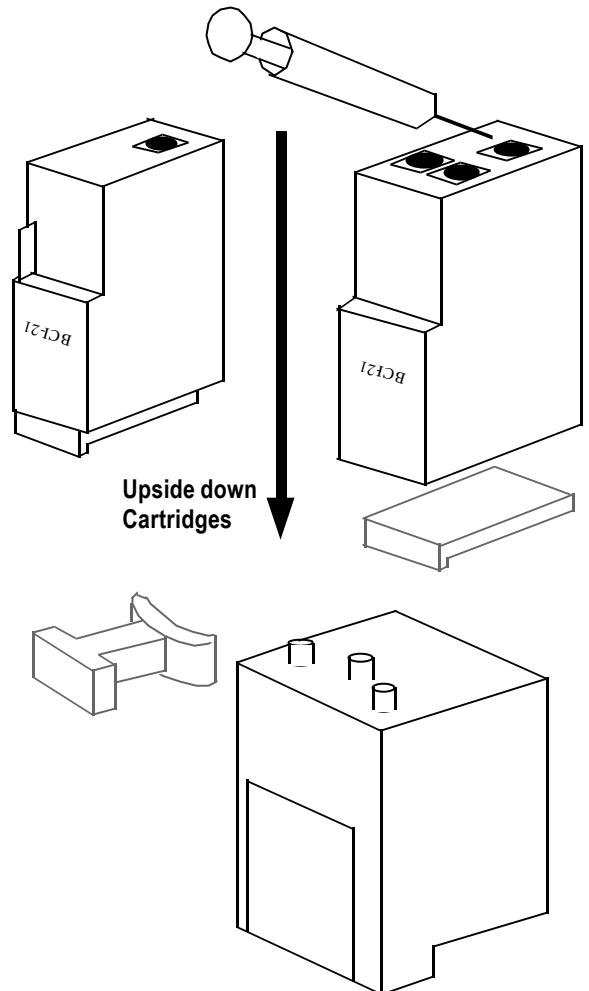

## OLIVETTI

### Colour cartridge

- ◆ Remove the cartridge from the printer.
- ◆ Remove the yellow cap. (the cap is not glued down)
- ◆ Follow the instructions for HP Deskjet 51625A from step three onwards.

### Black cartridge

- ◆ Inject 10 ml of black ink slowly in through the hole situated on top of the cartridge. (give the ink time to absorb into the sponge)

## TIPS

- ◆ Inject ink into the cartridge SLOWLY allowing the ink time to absorb into the sponge. This reduces the possibility of air locks and will also help avoid ink overflowing and mixing the colours.
- ◆ When filling the colour cartridge try to work out which compartment needs to be filled as the colours will not be used at the same rate. To do this, print a test print of three/five blocks of colour. The colour which is faint is the one which needs to be filled. Doing this will help to avoid over filling the cartridge.
- ◆ If the printhead is an integral part of the cartridge and the print head is blocked, the best cleaning fluid is steam. Simply hold the printhead over the steam from a kettle for about 30 seconds. Blow into the top to flush through any deposits. Do Not hold the cartridge too close as this will melt the contacts.
- ◆ If the printer is not accepting the cartridge try cleaning the contacts as stray ink may have got onto them.